

Manual

Flatlift Pop-Up 30/42"

FLATLIFT Pop-Up 30/42"

Notes of the system:

- Assembly dimensions Flatlift base
 - W=300mm D=200mm
- Assembly Flatlift
 - W=785mm D=135mm H=625mm
- Stroke 675mm
- Stroke speed 45mm/sec
- TV weight max. 35kg
- TV-Size 30-42"
- Duty cycle 18%
- Soft Start / Soft Stop
- Very silent
- Environmental temperature to work +5°C bis 40°C
- Connection to room control possible

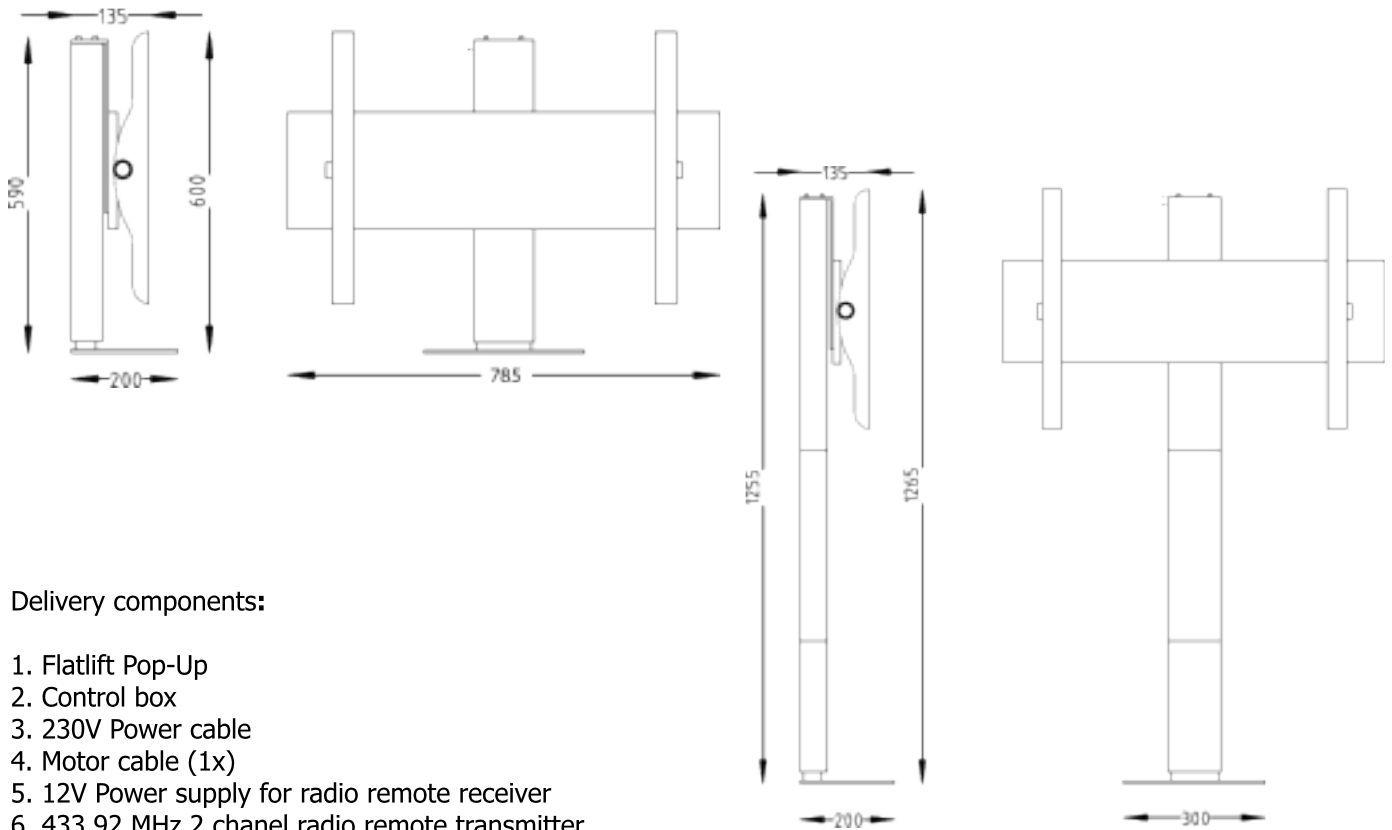

Delivery components:

1. Flatlift Pop-Up
2. Control box
3. 230V Power cable
4. Motor cable (1x)
5. 12V Power supply for radio remote receiver
6. 433,92 MHz 2 channel radio remote transmitter
7. 433,92 MHz 2 channel radio remote receiver

First installation:

1. Fix the Flatlift Pop-Up base with 4 screws (Abb.1 Nr.1) at the floor, so the system can't tilt.
2. Connect the Flatlift (Abb.1 Nr.3) with the motor cable (Abb.3) and the same with the control box (Abb.2 Nr.5) use connection "1".
4. Plug the RJ45 Western plug of the radio remote receiver (Abb.4 Nr.7) to the control box (Abb.2 Nr.6).
5. Connect the control box to line power (Abb.2 Nr.4) use power cable (Abb.5).
6. Connect the power supply of the radio remote receiver (Abb.4 Nr.8) to the line power.
8. Initialize the Flatlift by pressing the "Down button" at the radio remote transmitter for 10 seconds (Abb.6 Nr.9). Now drive the Flatlift two times completely up and down.
9. Your Flatlift now is ready to work.
10. Fix the TV on the Flatlift.

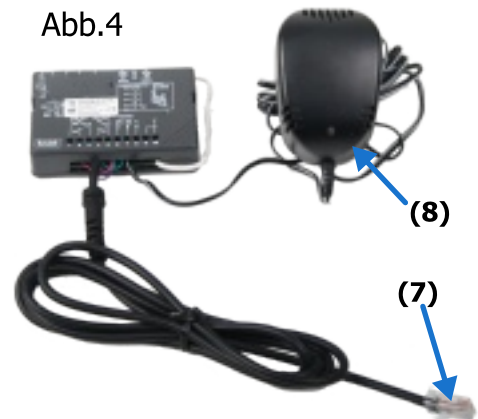
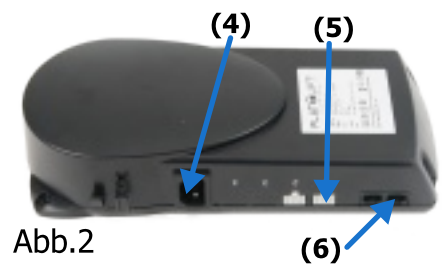
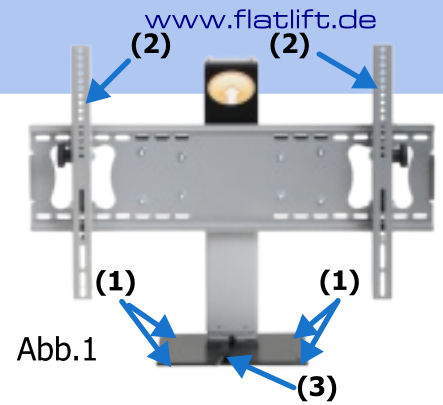

Every time you disconnect the control box of the Flatlift, you have to initialize the system with out a fixed TV.

Our system will only lift if you press a button. So if you stop pressing a button the Flatlift will stop. This feature is for security and demanded by law.

Diagnostics:

If you're Flatlift do not work correctly check the following points.

- Flatlift do not lift
 - Do have connect the control box to the power line?
 - Do you have power on the power plug?
- Have you plugged all plugs correctly to the control box (Attention wrong plugged plugs maybe damage the system)?
 - Check all plugs
 - Do you see any damage at the cable, the control box, the transmitter or the Flatlift?
 - Damaged components must be changed, please contact use.
- Your Flatlift stops and will only drive to the reverse side.
 - Have you reached the full stroke?
 - Do you assemble a TV which has a weight over the approved weight?
 - Mount a TV with lower weight and check again.
 - Do you radio remote transmitter work?
 - Take new battery inside the transmitter

Programm your radio remote transmitter to the receiver:

You can order some extra radio remote transmitter. The radio remote system use a code, so you have to programm new transmitter to the recioever.

- 1) Open the cover (Abb.7 Nr.10) at the receiver.
- 2) Press the left button (Abb.7 Nr.11) . The LED in the middle of the two buttons will flashing slowly(Abb.7 Nr.12).
- 3) Hold hte button (Abb.7 Nr.11) and press at the same time the left button on the transmitter (Abb.8 Nr. 13). The LED (Abb.7 Nr.12) will flashing very fast if the button is programmed.
- 4) Stop pressing the button (Abb.7 Nr.11)
- 5) For programming the second transmitter button repeat beginning step 2 and use the right button on the transmitter(Abb.8 Nr.14).

If the transmitter is corecctly programmed to the receiver you can here a "KLICK" if you press a button on the transmitter.



Abb.7



Abb.8

Reset the receiver:

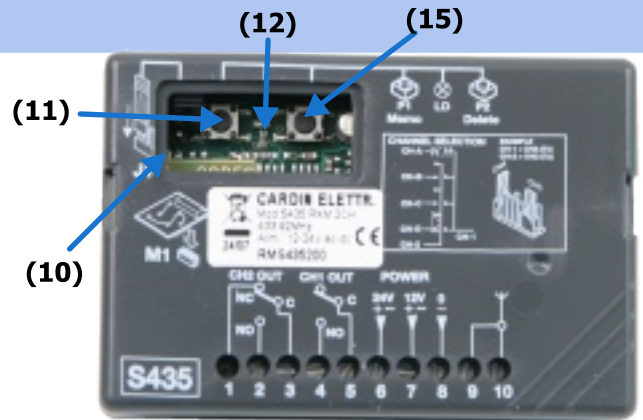
Some time it is possible the receiver loses some codes. If this happens you have to reset an programm the receiver new.

- 1) open the cover at the receiver (Abb.7 Nr.10).
- 2) Press the both buttons on the receiver(Abb.7 Nr.11 + 15). If the LED (Abb.7 Nr.12) is flashing very fast the receiver is reseted and you can stop pressing the buttons.
- 3) Now you have to programm the transmitter buttons to the receiver.

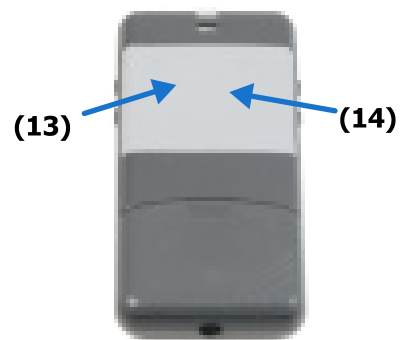
Connecting your Flatlift to room control:

You can connect your Flatlift to room control.

- 1) Disconnect the power supply of the radio remote receiver of the power line.
- 2) Disconnect the cables (feder clamp 2-4) at the receiver.
- 3) Connect the blue and red cable to one output of your room control (The room control need two potenzial free relays). This output is to lift down.
- 4) Connect the green and a brigde of the blue cable to the second output. This output is to lift up.
- 5) Please consider the room control have to switch the output for the hole time the lift have to drive up or down. It is not correct to switch only for a short signal.



Intended use

The product is only for lift TVs.

All corporate names and product synonyms are trademark of their owners.
All to reserve one's rights.

Delivery is conditioned of product and series

Please check the delivery for completeness and contact use inside 7 days if the delivery is not complete.

Safety instructions

The safety instructions should be observed without fail, so you will warrant a reliable work of your Flatlift.

Save the manual from a loss.

The guarantee will lapse if damage is caused as a result of non-compliance with the operating instructions.

We assume no liability for any consequent damage.

- For safety and certification reasons, unauthorised modifications and/or changes to the Flatlift are not permitted.
- The product is not a toy, keep kids away.
- The product must be dry and waterless.
- Be careful with the packaging material it will be dangerous for kids.
- Attention the product will be damaged by falling down from low highs
- Before you use your Flatlift the first time, please check there is no barricade for the Flatlift or the TV.

Quality

When we choose our components, we are looking for a good functionality, an easy handling and high security.

Thank you for your trust to our products.

With our individual customer service we will help you installing your Flatlift.

Contact use, we are happy to help you.

In this manual you will find a extra chapter for the customer service.

Service:

If there are some problems by installing or using your Flatlift please contact use.

Email: info@flatlift.com

Phone between 8:00-17:30 using +49 (0)62 41 – 97 20 10

If you contact use, we need the following informations:

- Type of Flatlift System
- Time when you buy the system
- Your customer number or the name of your retailer
- Dimensions and weight of the TV you fixed to the Flatlift
- Accessoires and appointments of your Flatlift

Flatlift TV Lift Systeme GmbH

Gewerbegebiet Südwest
Niedesheimer Straße 15

67547 Worms

Tel: 0049 6241 97 20 10

Fax: 0049 6241 97 20 12

Info@flatlift.de

www.flatlift.de

Geschäftsführer: Sascha Rissel

HRA Mainz: HRB 40436

Steuernummer auf Anfrage.

© by Flatlift TV Lift Systeme GmbH 2008

Flatlift- your perfect solution is a registered German / European Trademark

Pop-Up Patent Pending