

SaphIR 862P Eye Mini Plasma-friendly Infrared Receiver Installation Manual

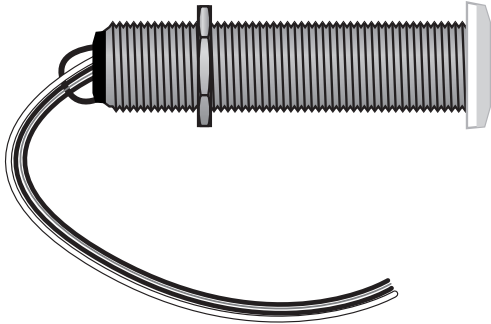

Bezel Exchange

The 862P Plasma Eye comes with three bezels (white, black, brass) for more installation color choices.

To remove the bezel, hold the barrel steady and upright and twist the bezel until it clears the top of the barrel. Make sure the small tinted plasma filter stays in place at the end of the barrel.

To replace the bezel, center the bezel over the filter and barrel, thread onto the barrel end and twist until snug.

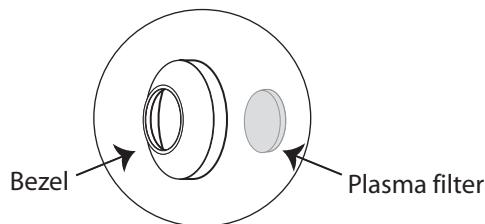

Product Overview

The 862P Eye Plasma-friendly IR Receiver receives IR signals from a handheld IR remote control and relays these signals to the audio-video equipment for operation from another room. It mounts through a circular hole with a diameter of 0.5" (1.27 cm), requires a minimum clearance of 2.0" (5.08 cm) behind the face of the mounting panel, and will mount in a panel with a maximum thickness of 1.75" (4.45 cm).

The blue talkback LED can be disabled by snipping the wire that loops out of the 860 near the leads.

Features

- Plasma-friendly - can be placed near plasma TVs and displays
- Comes with interchangeable white, black and brass bezels to easily customize your installation
- CFL friendly - allows installations in areas with compact fluorescent lighting. Works in most lighting environments.
- Blue IR confirmation LED
- Option to disable talkback LED
- Can easily be mounted in many in-wall speakers and custom cabinets
- Wide band IR receives IR from many types of remotes

Disable IR talkback LED

NOTE: Disabling the talkback LED should be performed PRIOR to wiring the 862P to the connecting block.

To disable the blue talkback LED of the 862P Eye, locate the small wire loop at the end of the receiver near the wire leads. Carefully snip the wire near the middle. If it is necessary to re-enable the LED, simply reconnect the leads.

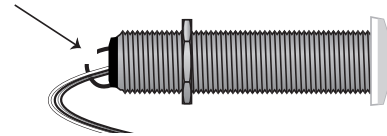

Limited Warranty

The Russound 862P IR Receiver is fully guaranteed for two (2) years from the date of purchase against all defects in materials and workmanship. For this warranty to apply, the unit must be installed and used according to its written instructions. During this period, Russound will replace any defective parts and correct any defect in workmanship without charge for either parts or labor. Accidental damage and shipping damage are not considered defects under the terms of this warranty. Russound assumes no responsibility for defects resulting from abuse or servicing performed by an agency or person not specifically authorized in writing by Russound. If service is necessary, it must be performed by Russound. Damage to or destruction of components due to excessive power voids the warranty. In these cases, the repair will be made at the owner's expense. To return for repairs, the unit must be shipped to Russound at the owner's expense, along with a note explaining the nature of the service required. Be sure to pack in a corrugated container with at least 3 inches of resilient material to protect the unit from damage in transit.

Before returning a unit for repair, call Russound at (603) 659-5170 for a Return Authorization number. Write the RA number on the shipping label and ship to: Russound, ATTN: Service, 5 Forbes Road, Newmarket NH 03857

Russound sells product only through authorized Dealers and Distributors to ensure that customers obtain proper support and service. Any Russound product purchased from an unauthorized dealer or other source, including retailers, mail order sellers and online sellers will not be honored or serviced under existing Russound warranty policy. Any sale of products by an unauthorized source or other manner not authorized by Russound shall void the warranty on the applicable product.

Installation

The SaphIR 862P Eye is installed into a circular hole 0.5" in diameter. Remove the nut from the receiver's barrel. Insert the Eye (wire end first) until the bezel is flush with the surface. Rethread the nut onto the barrel until it is snug against the rear of the mounting surface. If necessary, use one or both of the included washers for a more secure installation into soft or thin materials.

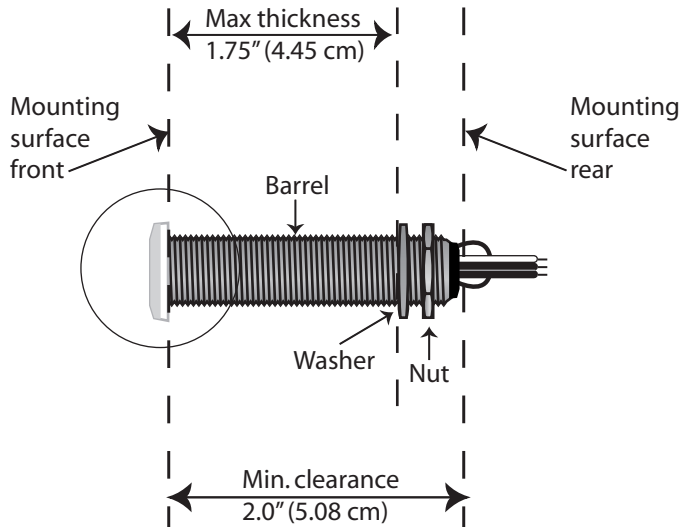

Wire Connections

Direct Connection from 862P Eye to Connecting Block

Connect the 862P Eye to the 857 connecting block. Connect GND (GROUND), IR (SIGNAL) and Voltage (+12VDC) to connector on the 857.

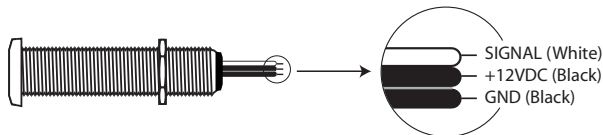
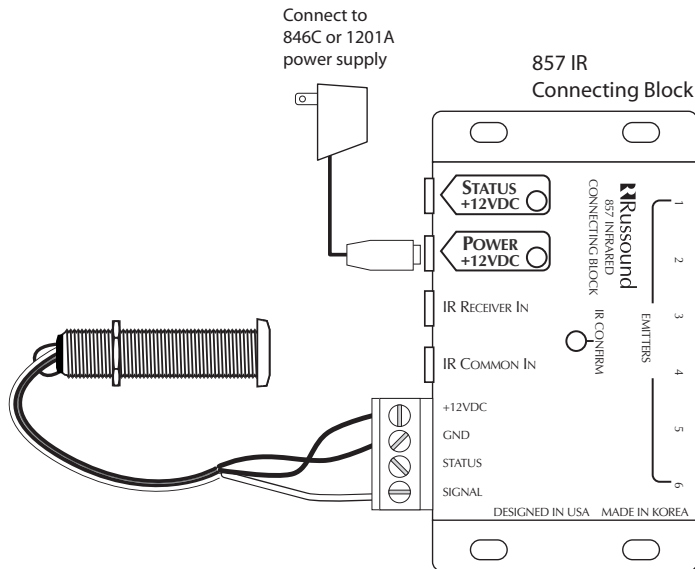

Wire Connections

Extended Leads from 862P Eye to Terminal Strip to Connecting Block

The extended connection between the IR receiver and the connecting block should be made with twisted-pair wiring (i.e., CAT-5e cable). It may be necessary to use shielded twisted-pair wiring if the wiring is exposed to interference from power wiring centers or from broadcast signals (FM, TV, etc.) located nearby. The installer should determine the cable type needed to suit the local conditions of the installation. A terminal strip is included for extending the leads.

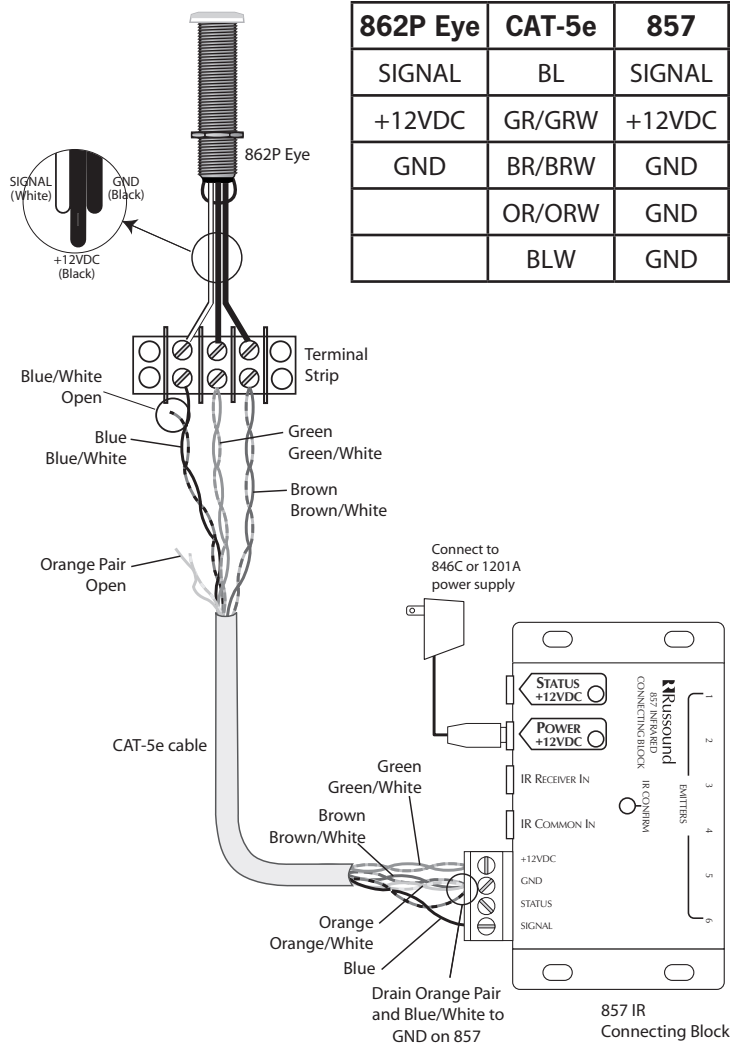

Specifications

- Receive Frequency: 36kHz to 58kHz
- Transmit Frequency: 40kHz and 56kHz
- Range: On Axis - 30ft to 50ft (9.1-15.2m)
30° Off Axis - 5ft to 15ft (1.5-4.6m)
- Power: 12VDC 31mA max.
- Dimensions: 0.46" Diameter x 2.03"D
(1.2cm Diameter x 5.16cm D)
- Mounting Cord Length: 6.5 ft. (1.95m)