

It's Under Control®

T3-V+

Universal System Controller

Operation Guide



70-210085-23 V1.0

FEDERAL COMMUNICATIONS COMMISSION NOTICE

This equipment has been tested and found to comply with the limits for a Class B digital device, pursuant to Part 15 of the FCC Rules. These limits are designed to provide reasonable protection against harmful interference in a residential installation.

This equipment generates, uses, and can radiate radio frequency energy and, if not installed and used in accordance with the instructions, may cause harmful interference to radio communications. However, there is no guarantee that interference will not occur in a particular installation.

If this equipment does cause harmful interference to radio or television reception, which can be determined by turning the equipment off and on, the user is encouraged to try to correct the interference by one or more of the following measures:

- Reorient or relocate the receiving antenna.
- Increase the separation between the equipment and the receiver.
- Connect the equipment into an outlet on a circuit different from that to which the receiver is connected.
- Consult the dealer or an experienced radio/TV technician for help.

This device complies with Part 15 of the FCC Rules. Operation is subject to the following two conditions:

1. This device may not cause harmful interference.
2. This device must accept any interference received including interference that may cause undesired operation.



Contains FCC ID: MMURTI 1500

Contains FCC ID: U9R-W2SW0001

Contains IC (Canada): 3166A-RTI 1500



For Indoor Use Only



117 612 914

DECLARATION OF CONFORMITY (DOC)

The Declaration of Conformity for this product can be found on the RTI website at: www.rticorp.com/declaration

SAFETY SUGGESTIONS

Read and Follow Instructions. Read all safety and operating instructions before operating the unit.

Retain Instructions. Keep the safety and operating instructions for future reference.

Heed Warnings. Adhere to all warnings on the unit and in the operating instructions.

Heat. Keep the unit away from heat sources such as radiators, heat registers, stoves, etc., including amplifiers that produce heat.

Do Not Open Battery Compartment. This device contains Lithium-Ion or Lithium-Polymer batteries. Batteries should only be replaced by an authorized service center or trained installer.

Power Sources. Connect the unit only to a power supply of the type described in the operating instructions, or as marked on the unit.

Power Cord Protection. Route power supply cords so that they are not likely to be walked on or pinched by items placed on or against them, paying particular attention to the cord plugs at power receptacles and at the point at which they exit from the unit.

Water and Moisture. Do not use the unit near water—for example, near a sink, in a wet basement, near a swimming pool, near an open window, etc.

Object and Liquid Entry. Do not allow objects to fall or liquids to be spilled into the enclosure through openings.

Servicing. Do not attempt any service beyond that described in the operating instructions. Refer all other service needs to qualified service personnel.

Damage Requiring Service. The unit should be serviced by qualified service personnel when:

- The power supply cord or the plug has been damaged.
- Objects have fallen or liquid has been spilled into the unit.
- The unit has been exposed to rain.
- The unit does not appear to operate normally or exhibits a marked change in performance.
- The unit has been dropped or the enclosure has been damaged.

WARNING!

**TO REDUCE THE RISK OF FIRE OR ELECTRIC SHOCK,
DO NOT EXPOSE THE UNIT TO RAIN OR MOISTURE.**

BATTERY WARNINGS

GENERAL BATTERY WARNING: Rechargeable Lithium batteries can explode, catch fire, and/or cause burns if disassembled, punctured, cut, crushed, short circuited, incinerated, recharged, or exposed to water, fire, or high temperatures. DO NOT place loose batteries in a pocket, purse, or other receptacle containing metal objects, mix with used or other battery types, or store with hazardous or combustible materials. If batteries catch fire, DO NOT attempt to put out the fire with water—use a class “D” fire extinguisher or other smothering agent. Keep batteries away from children. DO NOT tamper with wires or connectors that are attached to the battery. Failure to follow these directions could result in damage to your remote control that may not be covered by RTI’s warranty. Store lithium batteries in a cool, dry, ventilated area. Follow applicable laws and regulations for transport, shipping, and disposal. For more details on recycling lithium batteries please contact a government recycling agency, your waste disposal service, the reseller where the batteries were purchased, or visit a reputable online recycling source such as www.batteryrecycling.com.

COUNTERFEIT AND INFERIOR-QUALITY BATTERY WARNING: Counterfeit and/or inferior-quality lithium batteries are known to develop internal defects that can lead to fire and/or explosion. This can result in damage to your remote control, and in some cases, property damage or personal injury. Customers are specifically cautioned from purchasing batteries from online auction websites, as these are known sources of counterfeit or inferior-quality batteries. RTI’s rechargeable lithium batteries are manufactured to strict quality standards specifically for use in RTI remote control products, and contain built-in fault protection for added safety. The use of counterfeit or inferior-quality batteries could greatly reduce runtime and performance, damage your RTI remote control, constitute a safety hazard, and may void your warranty.

To make sure you get authentic RTI rechargeable lithium batteries purchase them only from www.rtiwebstore.com or an authorized RTI reseller.

LIMITED WARRANTY

Remote Technologies Incorporated warrants its products for a period of one (1) year (90 days only for included battery packs) from the date of purchase from Remote Technologies Incorporated or an authorized Remote Technologies Incorporated distributor.

This warranty may be enforced by the original purchaser and subsequent owners during the warranty period, so long as the original dated sales receipt or other proof of warranty coverage is presented when warranty service is required.

Except as specified below, this warranty covers all defects in material and workmanship in this product. The following are not covered by the warranty:

Damage resulting from:

1. Accident, misuse, abuse, or neglect.
2. Failure to follow instructions contained in this Guide.
3. Repair or attempted repair by anyone other than Remote Technologies Incorporated.
4. Failure to perform recommended periodic maintenance.
5. Causes other than product defects, including lack of skill, competence or experience of user.
6. Shipment of this product (claims must be made to the carrier).
7. Being altered or which the serial number has been defaced, modified or removed.

Remote Technologies Incorporated is not liable for any damages caused by its products or for its failure of its products to perform, including any lost profits, lost savings, incidental damages, or consequential damages.

Remote Technologies Incorporated is not liable for damages based upon inconvenience, loss of use of the product, loss of time, interrupted operation, commercial loss, any claim made by a third party or made by you for a third party.

Remote Technologies Incorporated's liability for any defective product is limited to repair or replacement of the product, at our option.

If your T3-V+ Universal System Controller needs service, please contact Remote Technologies Incorporated by telephone, fax or E-mail for return information. **Please do not return products to Remote Technologies Incorporated without return authorization.**

DISCLAIMER

All rights are reserved. No part of this document may be photocopied, reproduced, or translated without the prior written notice of Remote Technologies Incorporated.

The information contained in this document is subject to change without notice. Remote Technologies Incorporated shall not be liable for errors or omissions contained herein or for consequential damages in connection with the furnishing, performance, or use of this guide.

Microsoft, Windows, Windows XP, Windows Vista and Windows 7 are registered trademarks of Microsoft Corporation in the United States and other countries.

ZigBee is a registered trademark of the ZigBee Alliance.

T3-V+, *Integration Designer*, and the RTI logo are registered trademarks of Remote Technologies Incorporated.

Other brands and their products are trademarks or registered trademarks of their respective holders.

TABLE OF CONTENTS

Federal Communications Commission Notice	3
Safety Suggestions	4
Battery Warnings	5
Limited Warranty	6
Disclaimer	7
Table of Contents	9
Chapter 1 - Welcome	11
Features	11
IR Compatibility.....	12
Software Requirements	12
Unpacking and Inspection	12
Product Contents	12
Chapter 2 - Introduction	13
Important Notes	13
Cleaning	13
Battery and Docking Station.....	14
Getting Started	15
Remote Reference.....	16
Docking Station Reference	18
Button Keycap Replacement	19
Chapter 3 - Operation	21
Programming the T3-V+	21
The Touchscreen Display.....	21
The Control Panel Page.....	22
Backlight Level	23
Time Out	24
Tilt Switch.....	24
Battery.....	25
Sound	25
Calibrate Touchscreen.....	26
Network Information	27
Web Browser	27
Chapter 4 - Specifications	29
Chapter 5 - Troubleshooting	31
Chapter 6 - Service and Support	33
Index	35

CHAPTER 1 | WELCOME

Thank you for purchasing the T3-V+ Universal System Controller.

Representing the pinnacle of elegance, the T3-V+ is an extremely powerful controller wrapped in an easy-to-use, contemporary design. The third generation of the award-winning T3 system controller, the T3-V+ is enhanced with a state-of-the-art dual RF platform, improved WiFi[®] performance and updated hard button configuration. Experience the eye-popping color of the 3.5" full VGA touchscreen, offering a completely customizable user interface for intuitive command over the entire electronics system. Wireless Ethernet and a built-in web browser allow the user to access web pages and IP addressable devices such as security cameras. Like never before, the T3-V+ places powerful, stylish control in the palm of your hand.

FEATURES

- Dual RF transmission capability uses 433MHz and 2.4GHz (utilizing Zigbee[®] technology).
- Integrated 802.11b/g wireless Ethernet with improved performance.
- Two-way feedback from compatible devices using 2.4GHz (Zigbee[®]) and RTI control accessories.
- Blazing fast 533MHz CPU.
- Full VGA resolution (480x640) color TFT LCD to display custom buttons, text, graphics and animations.
- Integrated high-resolution touchscreen.
- Twenty-four programmable hard buttons, including five buttons with replaceable keycaps that can be custom engraved.
- Three-way rocker switch for scrolling list navigation.
- Ergonomic design permits effortless, one-handed operation.
- Tilt switch can automatically turn on the backlight when picked up.
- Extremely bright, backlit display and keypad.
- Transmits IR and RF (or both - on a single button press!).
- System includes a Lithium-Ion battery and docking station.
- Extremely wide IR transmitting frequency range.
- Optional 'Voltage' and 'Video' sensing modules to monitor power status of equipment when used with RTI processors.
- Capable of two-way RS-232 control when used with RTI control processors.
- Non-volatile Flash memory stores your system configuration even when power is not present.
- Fast USB 2.0 Programming.

CHAPTER 1 | WELCOME

IR COMPATIBILITY

The T3-V+ and *Integration Designer*® software are compatible with infrared (IR) commands with carrier frequencies between 15kHz and 460kHz, as well as those commands that do not use a carrier. This covers virtually all of the remotes that exist to date.

SOFTWARE REQUIREMENTS

The recommended minimum system requirements needed to run the *Integration Designer*® software are as follows:

- Windows XP®, Windows Vista®, Windows 7® or later version Microsoft operating system.

UNPACKING AND INSPECTION

After unpacking your new T3-V+ Universal System Controller, save all of the packing materials in case you ever have to ship the unit.

Thoroughly inspect the T3-V+ and packing materials for signs of damage. Report any damage to the carrier immediately. Report any equipment malfunctions to Remote Technologies Incorporated or an authorized Remote Technologies Incorporated distributor.

PRODUCT CONTENTS

Contents within the box include the following items:

- One (1) T3-V+ Universal System Controller
- One (1) Docking station
- One (1) Universal power supply for docking station
- One (1) Pen stylus
- One (1) Operation guide
- One (1) Keycap Removal Tool
- Five (5) Extra Keycaps

CHAPTER 2 | INTRODUCTION

IMPORTANT NOTES

Please read these important notes about the T3-V+:

- The T3-V+ should be placed in an area where it is around normal room temperature (between 60° F to 90° F). If the temperature is too hot, the display appears dim. If the temperature is too cold, the display appears dark and may respond slowly.
- Do not use sharp objects on the touchscreen. It is designed to operate with a touch of your finger.
- Do not let the T3-V+ get wet. It should not be handled with wet hands or placed in an area where it could get wet.
- Do not subject the T3-V+ to smoke, dust, or vibrations. The display may be damaged from excessive shock or vibration.
- Only use the power supply that is provided with the T3-V+. Using the wrong type of power supply may result in damage to the battery or electronic components.
- Do not disassemble the unit. Service of the T3-V+ should be performed by authorized personnel only.

CLEANING

Occasional cleaning may be required, depending on use. It is recommended that a "Clean" button is placed somewhere on the Home page of the T3-V+. This button should link to a page that does not contain commands or macros that could be inadvertently executed while cleaning the unit. The "Clean" page could contain a text message or graphic of your choosing such as:



To clean your T3-V+, lightly dampen a lint-free cloth with a glass cleaner or mild detergent, and wipe the touchscreen, keypad and outer surfaces.

CHAPTER 2 | INTRODUCTION

BATTERY AND DOCKING STATION

The T3-V+ uses a Lithium-Ion rechargeable battery. This battery does not exhibit any type of "Memory Effect" from being charged too often. Since the T3-V+ can safely be charged after each use, a docking station is included for convenience. The T3-V+ Docking Station can be placed on a flat surface such as a shelf or table, or it can be mounted to a wall using the mounting holes on the back of the unit.



If the T3-V+ battery capacity is reduced to approximately 25 percent, a low battery icon will appear in the top center of the display.



The low battery icon will change color to red if the battery capacity becomes critically low. At this point the T3-V+ must be placed into the docking station to recharge the

battery.

The docking station LED illuminates red to indicate a charge in progress. The LED will illuminate blue when the battery in the unit is fully charged or does not need to be charged. A fully discharged battery will take approximately 2-4 hours to completely re-charge.

CHAPTER 2 | INTRODUCTION

GETTING STARTED

NOTE: The following steps for initial installation including removing the battery door should be performed by an authorized service center or trained installer only.

Start by insuring the battery connector is inserted into the mating plug on the T3-V+. Make sure the connector is oriented properly before attempting to insert it. Next, turn the unit on by sliding the power switch into the "ON" position (toward the battery).

After power is applied, the T3-V+ will take approximately ten seconds to load the operating system, the application software, and the user program. This long delay only occurs from a power-down state. During normal use the T3-V+ turns-on instantly from its sleep mode.

The T3-V+ is turned-on by touching any area of the display or any keypad button. If the tilt sensor is enabled, picking up the unit will also turn it on.

POWER
SWITCH

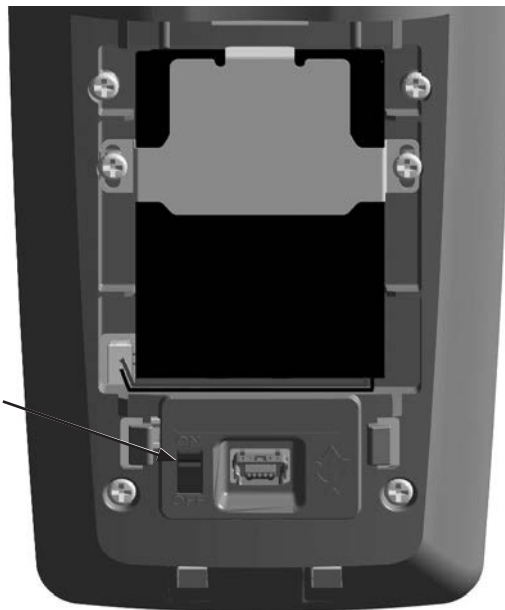

CHAPTER 2 | INTRODUCTION

REMOTE REFERENCE

FRONT



CHAPTER 2 | INTRODUCTION

BACK



CHAPTER 2 | INTRODUCTION

DOCKING STATION REFERENCE

TOP

CHARGE CONTACTS

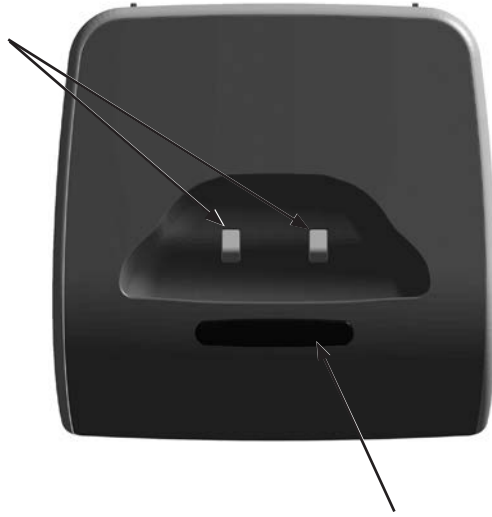

CHARGE LED

BACK

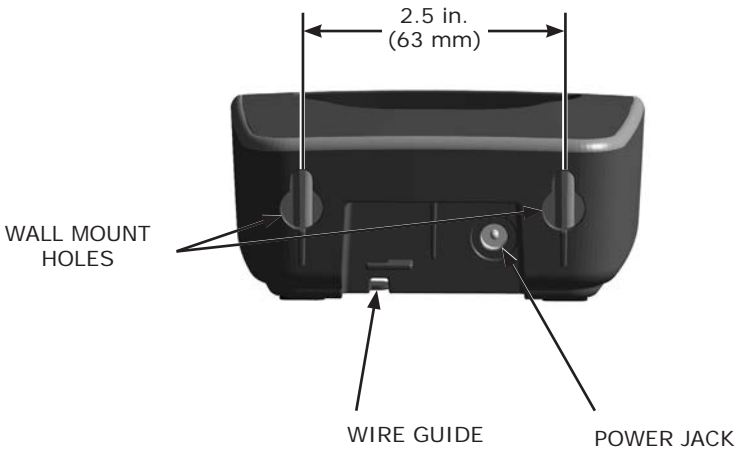

WIRE GUIDE

POWER JACK

CHAPTER 2 | INTRODUCTION

KEYCAP REPLACEMENT

The T3-V+ kit includes a set of extra keycaps. They can be used instead of the keycaps that are pre-installed on the five customizable keypad buttons located just below the touchscreen.

IMPORTANT NOTE: Do not attempt to replace any of the other button keycaps on the remote, as they are not designed to be removed.



KEYCAP INSTALLATION

IMPORTANT NOTE: To avoid accidental scratching of the remote surface, place a small piece of tape underneath the blade of the Keycap Removal Tool adjacent to the keycap.

- 1) Using the Keycap Removal Tool (supplied), align the tip of the tool with the inset groove located on the outside edge of the keycaps.
- 2) The keycaps are held in by a retaining clip. Gently pry up until the keycap is loose and finish removal with your fingers.
- 3) Select the replacement keycap you wish to use and align it with the top of the button on the remote, then press down till the retaining clips hold the keycap in place.

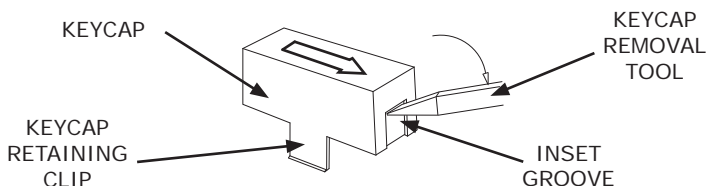

CHAPTER 2 | INTRODUCTION

CHAPTER 3 | OPERATION

PROGRAMMING THE T3-V+

The T3-V+ is programmed using *Integration Designer*® software. RTI dealers can download the software from:

www.rticorp.com/dealers

The required USB cable is included with the RTI IR-PRO dealer kit.

THE TOUCHSCREEN DISPLAY

The T3-V+ touchscreen display is organized into a series of pages. Normally each page contains objects (buttons, text, graphics, etc.) that are related in some way. For instance, they may all display information necessary for controlling a particular DVD player.

By default, the T3-V+ has one Home page—all other pages are normally accessed from links on the Home page. In addition, any page can contain buttons with a link to any other page.

Normally the Home page is used to display the names of the A/V sources and other devices being controlled. The T3-V+ will support 200 pages including the Home page.

A representation of a programmed Home page is shown below:



CHAPTER 3 | OPERATION

THE CONTROL PANEL

The Control Panel page can be displayed by first setting the T3-V+ power switch to the *off* position, and then

- Pressing and holding the touchscreen while sliding the power switch to the *on* position.

or

- Pressing and holding the “Home” keypad button (the “Home” button is the middle keypad button located in the row of five buttons closest to the touchscreen) while sliding the power switch to the *on* position. Continue holding the button until the “loading” bar begins to move across the screen, then remove your finger from the button.

NOTE: you must remove your finger from the keypad button before the “loading” bar has finished or it may not access the Control Panel.



or

- You can also access the Control Panel page by assigning a “Control Panel” page link to a button using the *Integration Designer*® software. To return to the user program, either press Exit or the Home button.

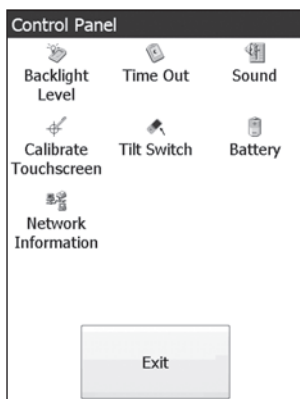

CHAPTER 3 | OPERATION

BACKLIGHT LEVEL (Ambient Light Sensor Enabled)

If the light sensor is enabled, there are two backlight levels to adjust. Press the left arrow or right arrow buttons to adjust. Press the OK button when finished. With the light sensor enabled, the backlight brightness will automatically change between the two levels, depending upon the ambient lighting conditions.

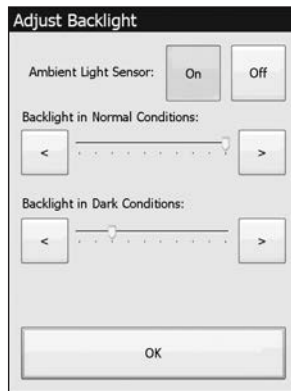

BACKLIGHT LEVEL (Ambient Light Sensor Disabled)

This button displays a window that allows you to adjust the backlight brightness and enable/disable the Ambient Light Sensor.

If the light sensor is disabled, there is only one backlight level to adjust. Press the left arrow or right arrow buttons to adjust. Press the OK button when finished. With the light sensor disabled, the backlight brightness will always stay at the same level whenever the T3-V+ is turned-on.

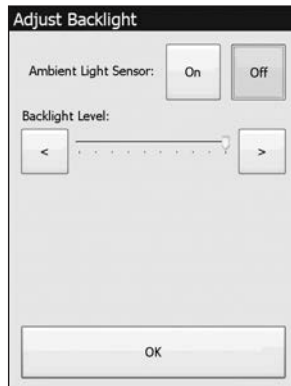

CHAPTER 3 | OPERATION**TILT SWITCH**

This button displays a window that allows you to adjust the settings for the built-in tilt sensor. The tilt switch is a motion detector that turns the remote on when activated. Press the OK button when finished.

On means the tilt switch is active and will wake-up the T3-V+ when it is moved.

Off means the tilt switch is inactive.

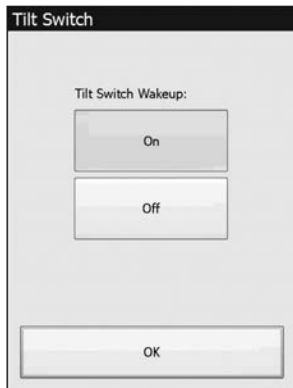
**TIME OUT**

This button displays a window that allows you to adjust the amount of time the unit stays awake after the last button press. The time is variable from 1 second to 120 seconds (the default is 10 seconds). Press the arrows to the left or right of the Time Out setting to adjust the time. Press the OK button when finished.

Note: This setting can have a significant effect on the run-time of the T3-V+ between battery charges. During Sleep mode, the T3-V+ uses virtually no battery power.

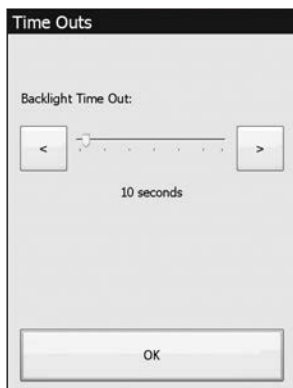

CHAPTER 3 | OPERATION

BATTERY

This button displays a window that allows you to adjust the relative amount of time that the low battery icon appears on the display.

This setting will determine how much time you have between the appearance of the low battery warning and the battery becoming completely depleted. The default warning time is Medium. Depending upon the age of the battery and daily usage habits, it may be beneficial to adjust this time. Press the OK button when finished.



SOUND

This button displays a window that allows you to adjust the volume of the audible speaker. The speaker sound provides feedback that a button was pressed. Press the arrows to the left or right to adjust the volume. There are six discrete volume settings. The lowest setting disables the speaker. Press the OK button when finished.

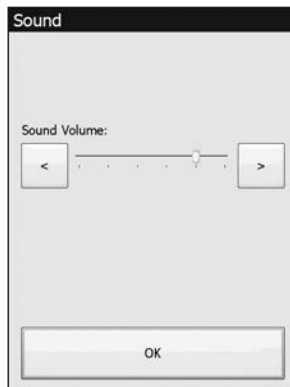

CHAPTER 3 | OPERATION

CALIBRATE TOUCHSCREEN

This button runs a routine that allows you to calibrate the touchscreen. Since it normally should not be necessary to calibrate the touchscreen, this routine is included as a precaution only.

Press the Calibrate button to continue.



Follow the directions on the display to complete the calibration process.

WARNING!

DO NOT ATTEMPT TO CALIBRATE THE TOUCHSCREEN WITH YOUR FINGERTIP. PROPER CALIBRATION REQUIRES A STYLUS OR OTHER FINE TIP. DO NOT USE METAL OBJECTS SUCH AS BALL POINT PENS OR SCREWDRIVERS THAT CAN DAMAGE THE SURFACE OF THE TOUCHSCREEN.

CHAPTER 3 | OPERATION

NETWORK INFORMATION

This button displays a window that allows you to view the wireless networking information. This is for troubleshooting purposes only, all networking configuration must be made in Integration Designer®. Press the OK button when finished.

The Mode field will show "Disabled" if it is disabled or "Not Connected" if it is enabled but does not have an active wireless connection. The Enable button does not take effect until the OK button is pressed. If you are enabling the adapter and want to see the signal strength - press ON, then press OK, then choose the "Network Information" button from the control panel again.

NOTE: Wireless Ethernet range will vary between 25-50 feet depending on many variables, including but not limited to:

- 1) Type of router used.
 - 2) Environmental factors such as building materials.
 - 3) Other wireless networks and devices using the 2.4GHz frequency.
- To maximize wireless networking range, try using a high quality router and/or installing additional wireless networking access points.

The screenshot shows a window titled "Network" with the following fields and controls:

- Mode: Connected
- IP: 192.168.0.1
- Mask: 255.255.255.0
- GW: 192.168.0.254
- DNS: 1.2.3.4
- MAC: 00-11-22-33-44-55
- SSID: testnet
- Wireless Signal Strength: [Signal strength indicator]
- Enable: On [radio button] Off [radio button]
- OK [button]

WEB BROWSER

The T3-V+ includes Internet Explorer® for browsing on the Internet. Although the browser is compatible with most website content including web pages that require Flash® (version 7 or lower), please note that plug-ins such as JAVA® and ActiveX®, streaming video, and persistent cookies are not supported.

A graphical representation of a keyboard will automatically pop up on the display whenever text entry is required. The keyboard can be dragged around the display by using its title bar. It can be dismissed by touching anywhere on the display that is outside of the keyboard.

CHAPTER 4 | SPECIFICATIONS

Power	3.6 VDC, 1700 mAh Lithium-Ion Battery Pack
Power Management	Automatic On/Off (tilt switch)
Infrared Control Range	30 feet (9.1 meters) @ 60 degrees
Infrared Frequency Transmission Range	15 kHz - 460 kHz
Radio Frequency Control Range	Up to 100 feet (30.5 meters) with optional System Interfaces/Processors
Radio Frequency Carrier	802.15.4 @ 2.4 GHz (ZigBee® Wireless Mesh Networking) and 433MHz
Wireless Ethernet	802.11g @ 2.4 GHz
Wireless Ethernet Security Protocols	64-bit WEP, 128-bit WEP, WPA TKIP and WPA2
Operating Temperature	+32° F to +122° F (0° C to +50° C)
Operating Humidity	5% to 95% Non-condensing
Touchscreen Display	High Brightness color TFT LCD Full VGA (480 x 640) pixels) with 65 K colors Integrated high-resolution touchscreen
Display Size	3.5 in (89 mm) diagonal
Backlights	White LED (display), Blue/Red/White LED (keypad)
Nominal Run Time on Full Charge	3.5 hours minimum, continuous use (5 to 7 days on average use)
Standby Time on Full Charge	30 days
Battery Charge Time	3 to 4 hours
System Memory	128 MB Flash (non-volatile) memory
Device Capability	Total number of devices is limited only by memory
Macro Capability	Unlimited steps in a single macro Total number of macros is limited only by memory Macro capability on every button
Communications	USB programming port
Dimensions (L x W x D)	7.6 in (193 mm) x 3.1 in (79 mm) x 1.1 in (28 mm)
Enclosure	High-impact molded ABS plastic
Weight	7.4 oz. (210 g) with battery pack
Warranty	One Year (Parts & Labor) / 90 days on battery

All specifications subject to change without notice.

CHAPTER 5 | TROUBLESHOOTING

If you are having problems with your T3-V+ Universal System Controller, please read the information below before contacting technical support.

If you continue to have problems, see Chapter 6 for more information on contacting RTI technical support.

DISPLAY IS DIM, BLANK OR UNREADABLE

- Make sure the battery pack connector is attached properly and the battery is charged.
- Try adjusting the backlight level from the Control Panel page (Refer to Chapter 3 for more details). By nature, the contrast of an LCD screen changes with temperature, so if the remote is cold the display will be dark and will return to normal as it warms.

USB COMMUNICATIONS PROBLEMS

- Verify that your PC is running Windows XP[®] or higher.
- Verify that the T3-V+ USB driver was installed the first time the T3-V+ was connected to your PC.
- Verify that the T3-V+ is present in the Device Manager within the Windows[®] Control Panel.
- Make sure you are using the programming cable that was supplied by RTI and that both ends are connected securely.
- Make sure the PC detects the presence of the T3-V+. If it doesn't, unplug the USB cable, wait for about ten seconds, and plug it in again.
- If the download fails after some data has been transferred, try re-sending the program.

IR CODE PROBLEMS

- If you are using an IR repeater system, make sure it is working correctly with the original OEM remote. If not, you will need to troubleshoot the IR repeater system.
- If you are still having problems, try adjusting the IR code "Minimum Repeats" value in the Integration Designer[®] programming software.
- If the IR code is executed inside a macro that contains multiple IR codes, try inserting a small time delay before the problem code. If there already is a delay, try increasing it.

CHAPTER 6 | SERVICE AND SUPPORT

For news about the latest updates, new product information, and new accessories, please visit our web site at:

www.rticorp.com

CONTACTING RTI

For general info, you can contact RTI at:

Tel. (952) 253-3100

Fax (952) 253-3131

info@rticorp.com

RTI TECHNICAL SUPPORT

At RTI, customer service and satisfaction is an utmost priority. If you are encountering any problems or have a question about your RTI product, please contact RTI Technical Support for assistance.

RTI provides technical support by telephone, fax or e-mail. For the highest quality service, please have the following information ready, or provide it in your fax or e-mail.

- Your Name
- Company Name
- Telephone Number
- E-mail Address
- Product model and serial number (if applicable)

If you are having a problem with hardware, please note the equipment in your system, a description of the problem, and any troubleshooting you have already tried.

If you are having a problem with software, please note what version you have installed, the operating system on your PC, a description of the problem, and any troubleshooting you have already tried.

If you are calling about a software or programming question or problem, please be at you computer when you place your call. This will considerably speed up the troubleshooting process.

For technical support or assistance with your T3-V+, software, or accessories, contact RTI at:

(952) 253-3137

support@rticorp.com

www.rticorp.com

For questions regarding service or repair of your T3-V+, contact RTI at:

(952) 253-3136

service@rticorp.com

www.rticorp.com

Please do not return products to RTI without return authorization.

CHAPTER 6 | SERVICE AND SUPPORT

Shipment of T3-V+ for Service

RTI will pay all labor and material expenses for all repairs covered by this product's warranty. If necessary repairs are not covered by warranty, or if a unit is examined which is not in need of repair, you may be charged for the repairs or examination.

If it is necessary to ship the T3-V+ Universal System Controller for service:

- Please pack it securely (we suggest that it be insured).
- Do not include accessories such as power cords or manuals unless instructed to do so.

You must pay any shipping charges incurred in getting your T3-V+ Universal System Controller to RTI. RTI will pay reasonable return shipping charges via a carrier of our choice to any destination within the United States if the repairs are covered under warranty.

A copy of the original dated sales receipt must be provided whenever warranty service is required. You will need this receipt to establish the date of purchase.

INDEX

Battery and Charging	14
Battery Warnings and Disposal	5
Button Keycap Replacement	19
Cleaning	13
Contents	9
Control Panel	22
Backlight	23
Battery	25
Calibrate Touchscreen	26
Network Information	27
Sound	25
Tilt Switch	24
Time Out	24
Disclaimer	7
Docking Station	14
Docking Station Reference	18
Features	11
Federal Communications Commission Notice	3
Important Notes	13
Introduction	13
Remote Reference	16
IR Compatibility	12
Limited Warranty	6
Operation	21
Product Contents	12
Programming the T3-V+	21
Safety Suggestions	4
Service and Support	33
Contacting RTI	33
RTI Technical Support	33
Shipment of T3-V+ for Service	34
Software Requirements	12
Specifications	29
Troubleshooting	31
Unpacking and Inspection	12

It's Under Control®



Remote Technologies Incorporated
5775 12th Avenue East, Suite 180
Shakopee, MN 55379
Tel: 952-253-3100
Fax: 952-253-3131
www.rticorp.com